

Kannad Marine Rescuer 2

SEARCH & RESCUE TRANSPONDER USER MANUAL

WARNING

- i This SART is an emergency device for use only in situations of grave and imminent danger.
- i False alarms cost lives and money. Help to prevent them; understand how to activate and disable your equipment.
- i Read the complete manual before installing, testing or using the SART.
- i The SART contains no user serviceable parts. Return to your dealer for service.
- i Dispose of this device safely. Contents include Lithium batteries; do not incinerate, puncture, deform or short-circuit.
- i This device emits radio frequency radiation when activated. Because of the levels and duty cycles, such radiation is not classed as harmful. However, it is recommended that you do not hold the radome while the SART is activated.
- i If the security tab is broken, the SART is not compliant with SOLAS regulations and must be repaired or replaced.

Transportation

The SART contains a primary non-rechargeable Lithium battery, and may have special transportation requirements depending on local and international regulations in force at the time.

The battery pack contains 6.2g Lithium in total. Transport the SART in compliance with applicable regulations for this mass of hazardous material.

For further information refer to the Kannad Marine website: -
www.kannadmarine.com

Disclaimer

The information and illustrations contained in this publication are to the best of our knowledge correct at the time of going to print. We reserve the right to change specifications, equipment, installation and maintenance instructions without notice as part of our policy of continuous product development and improvement. No part of this publication may be reproduced, stored in a retrieval system or transmitted in any form, electronic or otherwise without permission in writing from Kannad Marine. No liability can be accepted for any inaccuracies or omissions in the publication, although every care has been taken to make it as complete and accurate as possible.

CONTENTS

1.	General Description	2
2.	SART principle of operation	3
3.	Installation	5
4.	SART General Assembly	6
5.	Operating instructions	7
6.	Self test facility	8
7.	Battery replacement	9
8.	Technical description	10
9.	Function chart	11
10.	Fault Finding	11
11.	Servicing	11
12.	Dimensions	12
13.	Operation of marine radar for SART detection	13
13.1	Radar Range Scale	13
13.2	SART Range Errors	13
13.3	Radar Bandwidth	13
13.4	Radar Side Lobes	13
13.5	Detuning the Radar	13
13.6	Gain	13
13.7	Anti-Clutter Sea Control	14
13.8	Anti-Clutter Rain Control	14
13.9	Radar Displays	14
14	Technical Specification	15
15	Product Warranty	16
16	End of Life Statement	17
16.1	Battery Removal	17
16.2	Disposal	17

1. General Description

The SART (**S**earch **A**nd **R**escue **T**ransponder) is designed for survivor location during search and rescue operations.

CARRY-OFF SART

Supplied as one integral unit. This is normally mounted in a bulkhead bracket (supplied) which is used to stow the unit on the mother vessel. On abandoning to a the SART can be carried in one hand off the stricken vessel and mounted through a port in the canopy of the using the telescopic pole.

The main body of the SART is high visibility orange thermoplastic, attached to the sealed replaceable battery pack by stainless steel fastenings. The joint is sealed against water ingress by an O-ring.

Operation is by a rotating switch ring providing ON, OFF and TEST functions. The ON position is reached by breaking a security tab. The switch ring is spring loaded so that it returns automatically from the TEST position.

The Lithium battery is fitted with internal overload protection and has a five year storage life. Non-reversible electrical connections are provided in the SART body and battery pack to facilitate battery replacement.

Each SART carries a unique serial number and this can be located on the label affixed to the orange body.

SART

Supplied with or without mast. The SART is normally packed as part of the equipment. The mast version is mounted in the same manner as the carry-off version. The version without the mast is intended to be hung from the highest point inside the .

The SART itself is identical with the carry-off version.

2. SART principle of operation

Activating a SART enables a to be displayed on a search vessel's radar screen as an easily recognised series of 12 dots.

RADAR (radio detection and ranging) is a device carried by most ships which is used to determine the presence and location of an object by measuring the time for the echo of a radio wave to return from it, and the direction from which it returns.

A typical ship's radar will transmit a stream of high power pulses on a fixed frequency anywhere between 9.2GHz and 9.5GHz. It will collect the echoes received on the same frequency using a display known as a Plan Position Indicator (PPI), which shows the ship itself at the centre of the screen, with the echoes dotted around it. Echoes further from the centre of the screen are thus further from the ship and the relative or true bearing of each echo can be easily seen.

The SART operates by receiving a pulse from the search radar and sending back a series of pulses in response, which the radar will then display as if they were normal echoes. The first return pulse, if it sent back immediately, will appear in the same place on the PPI as a normal echo would have done. Subsequent pulses, being slightly delayed, appear to the radar like echoes from objects further away. A series of dots is therefore shown, leading away from the position of the SART. This distinctive pattern is much easier to spot than a single echo such as from a radar reflector. Moreover, the fact that the SART is actually a transmitter means that the return pulses can be as strong as echoes received from much larger objects.

A complication arises from the need for the SART to respond to radars which may be operating at any frequency within the 9GHz band. The method chosen for the SART is to use a wideband receiver (which will pick up any radar pulses in the band), in conjunction with a swept frequency transmitter. Each radar pulse received by the SART results in a transmission consisting of 12 forward and return sweeps through the range 9.2GHz to 9.5GHz. The radar will only respond to returns close to its own frequency of operation (i.e. within its receive bandwidth), so a "pulse" is produced at the radar input each time the SART sweep passes through the correct frequency. The text and diagrams on Page 14 show this in more detail.

A slow sweep would give the radar a stronger echo to deal with as the sweep would be inside the operating bandwidth for a longer period. The delay for the sweep to reach the operating frequency may however lead to an unacceptable range error, as delayed echoes appear to be coming from more distant objects.

To minimise this problem, the SART uses a "sawtooth" response, sweeping quickly, then slowly for each of its twelve forward and return sweeps. At long range, only the slow sweeps, giving the strongest returns, are picked up. At close range, where errors are more important, the fast sweeps are also detected. As the first sweep is a fast one, then the range error is minimised and should be less than 150 metres.

The timescale over which all this occurs is very short. Each "fast" sweep takes about 0.4³ s, each "slow" sweep about 7.5³ s. The complete series of twelve forward and return sweeps is therefore complete within 100³ s. Displayed on the PPI; the spacing between each pair of dots will be 0.6 nautical miles.

On a long range setting, a typical radar will be triggering the SART every millisecond - but only during the period that the rotating radar scanner is pointing in the correct direction. Most modern radars use sophisticated noise rejection techniques, which prevent the display of echoes which are not synchronized with the radar's own transmissions, so one radar will not normally be confused by a SART's response to a neighbouring radar.

The SART indicates that it has been triggered by lighting an indicator LED continuously (it flashes in standby mode) and by sounding an integral buzzer. If no radar pulses are detected for a period exceeding 15 seconds, the SART reverts to "standby" mode.

3. Installation

The preferred mounting location is inside the vessel, and protected from the elements, usually on the ship's bridge wing. The SART should be mounted where it will not get in the way of day-to-day operations, but where it can readily be accessed near an emergency exit in the event it is needed.

Do not install the SART within the ship's radar beam.

Fix the mounting bracket to a bulkhead in a convenient location. The recommended fixing is by M5 marine grade stainless steel (e.g. A4/316) bolts; length is dependent upon application. The bolts should be secured with either stainless steel locking nuts or stainless steel nuts with stainless steel shake proof washers.

Mount the SART, dome uppermost, onto the bracket by locating the lugs on the SART pole mount into the slots in the bracket. Push the SART down firmly into place.

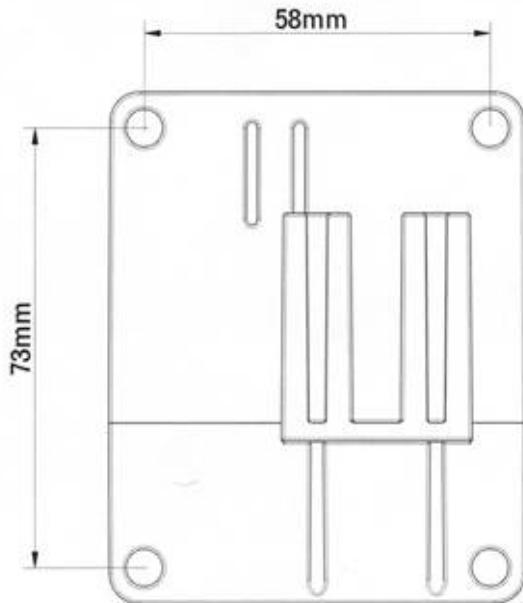
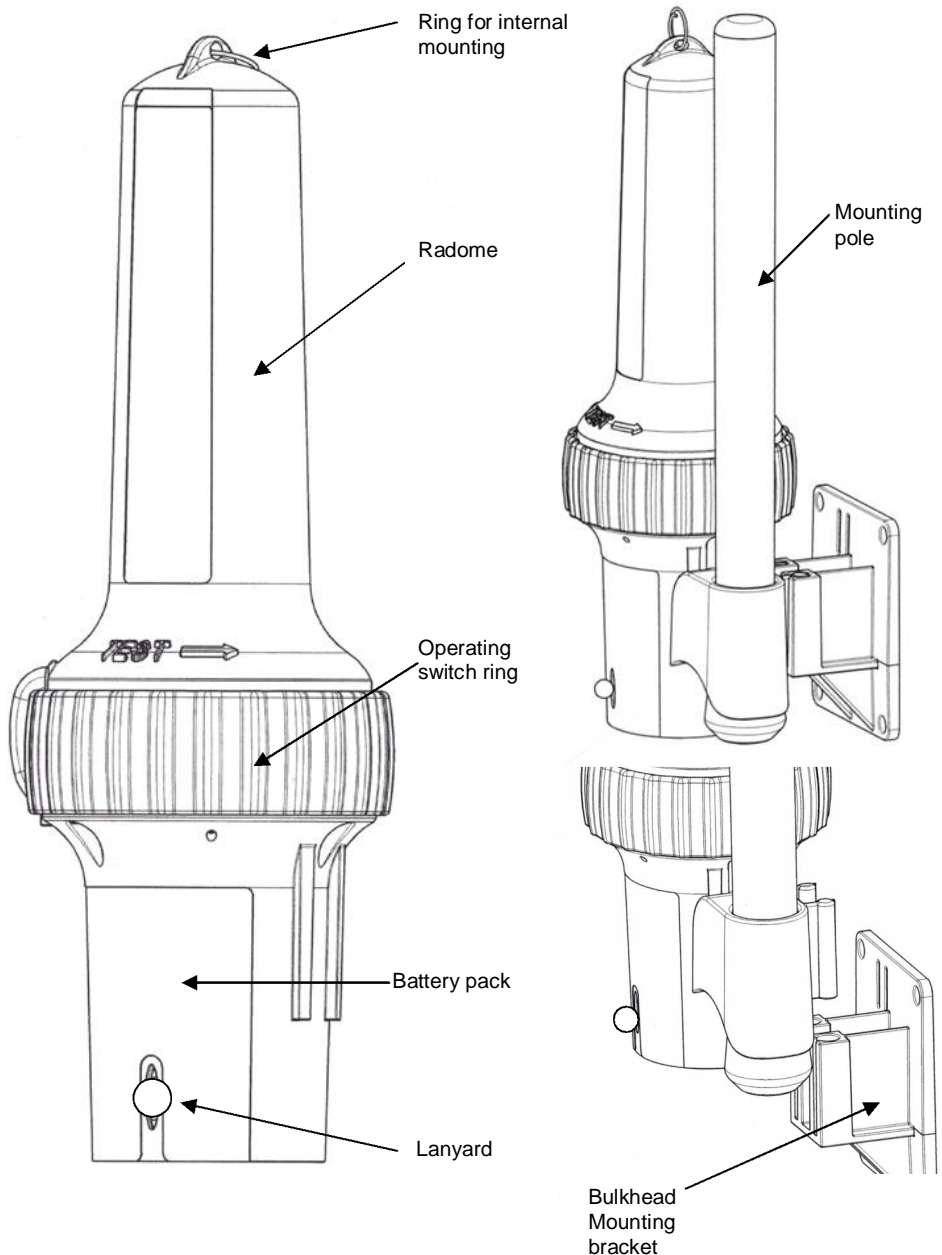

Figure 1
Bracket mounting holes: 4 holes, 5.5mm diameter

NOTE: Safe compass distance 1.5m.

4. SART General Assembly



5. Operating instructions

To remove from the bulkhead bracket:

Lift SART away from bracket

To switch on:

Break the security tab away from the body of the SART

Rotate the switch ring clockwise (i.e. to the left) to the ON position marked by "1"

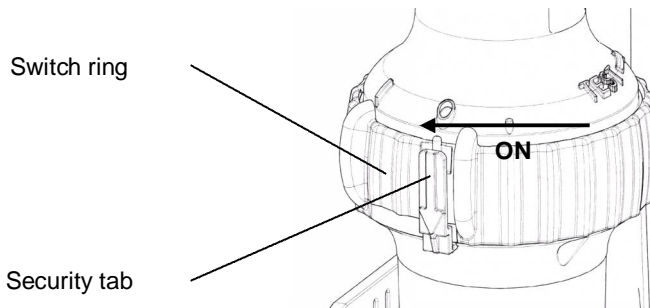

To extend the telescopic pole:

1. Grasp rubber cover at bottom of pole, and twist the pole to release it in the pole mount. Pull the pole down and twist to lock in place in the pole mount
2. Remove rubber cover from bottom of pole; allow pole sections to drop. Lock sections together by twisting each section.

To deploy in a :

Extend the SART supporting pole as detailed above

Tether the SART to a suitable point using the lanyard which unwinds from its base.

Insert the SART through the port in the canopy

Position the bottom of the support pole in the antenna pocket

Secure the pole to the canopy support.

Depending on the model, the mounting patch can also be located on the outboard side of the at the doorway entrance on the boarding ramp side.

The SART is mounted in the same way except the pole is secured to the buoyancy support.

Some 's have the SART already packed as part of the inventory. In general, these models of SART are not fitted with the support pole. The SART should be switched ON then suspended by its top loop from the highest point of the .

If the lanyard becomes unwound, it may be rewound by rotating the spool in the base of the SART in the direction of the arrow.

6. Self test facility

Regular testing of the SART is advised. The duration of the test should be limited to as short a time as possible as the SART response may be received by other vessels which are within range.

There are no operational differences between TEST and ON modes; the rotary switch must be held in the TEST position, on release it returns to the OFF position.

1. Ensure compliance with all applicable Health and Safety instructions when working in proximity to a radar transmitter.
 2. Locate the SART within the line of sight of operating approved marine Radar.
 3. Rotate the switch ring anticlockwise (i.e. to the right) to the TEST position, and hold it in this position for a minimum of 30 seconds.
 - a) If the SART responds to the radar, the red light in the base of the SART will be continuously lit and the buzzer will sound every 2 seconds. Ensure the SART meets this requirement for the full 30 seconds.
 - b) If the SART does not respond to the radar, the red light will flash every 2 seconds and the buzzer will not sound.
- If the SART does not respond to the radar for the full 30 seconds it has failed the test.
4. Switch off the SART by releasing the switch ring; check that it returns fully to the OFF position.
 5. During the annual survey, perform the self test and verify the SART performance by observing the response on the radar.

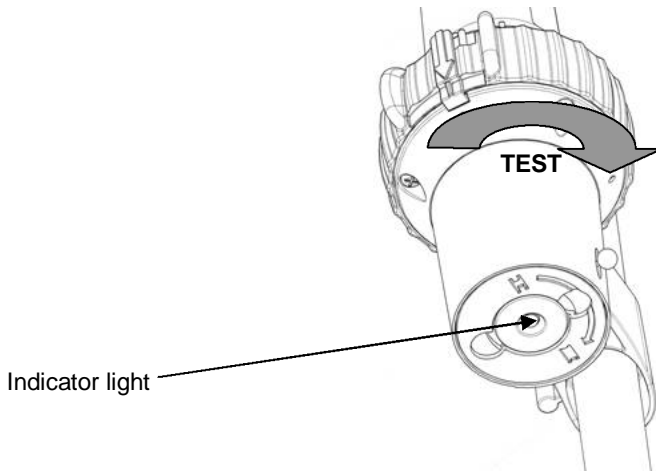

7. Battery replacement

The battery should be changed 5 years from the date of manufacture shown on the label or after use.

It is recommended that battery change should only be performed by an authorised Kannad Marine service agent, in order that a complete assessment and integrity check can be performed. The replacement battery kit is Kannad Marine part number 86-630A and contains all necessary components.

8. Technical description

A single switched antenna is used for both receive and transmit functions; the switch normally connects the antenna to the receiver circuit. In the standby state only the receiver portion of the SART is powered to reduce battery consumption to a minimum. In this condition the indicator circuit causes the LED to flash once every two seconds.

On receipt of a radar pulse the video amplifier and detector circuit causes the rest of the circuitry to become active and the unit switches to transmit mode. In this condition the indicator circuit causes the LED to remain steady and the buzzer to sound every two seconds.

The detection of a radar pulse causes the switch to connect the antenna to the transmitter circuit. The output stage is fed by a Voltage Controlled Oscillator (VCO), whose frequency is determined by a sweep generator. When triggered by the detector the sweep generator turns on the VCO and causes it to produce exactly 12 forward and reverse frequency sweeps before shutting down again.

If no radar pulses are detected for a period of 15 seconds the unit reverts to standby mode.

9. Function chart

SART STATUS	BUZZER	RED LED
OFF	OFF	OFF
STANDBY MODE (TEST or ON)	OFF	FLASHING EVERY 2 SECONDS
ACTIVELY TRANSPONDING (TEST or ON)	ON EVERY 2 SECONDS	ON

10. Fault Finding

Fault finding is limited to performing the self test and verifying the SART response on the radar.

11. Servicing

The SART contains no user-serviceable parts, and consequently should be returned to an authorised Kannad Marine service agent for repair. Ensure compliance with the appropriate regulations for transportation of Lithium material, as detailed in the Transportation section on the front inside cover.

12. Dimensions

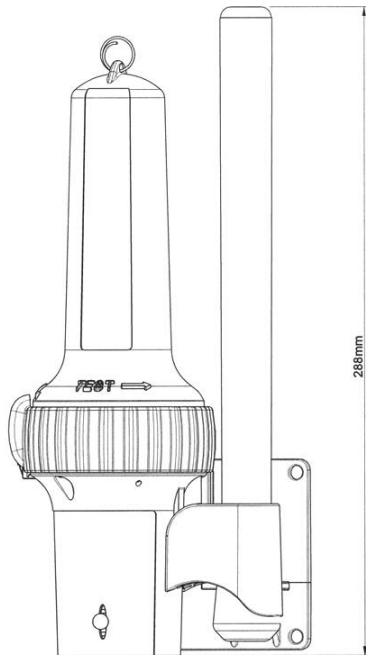
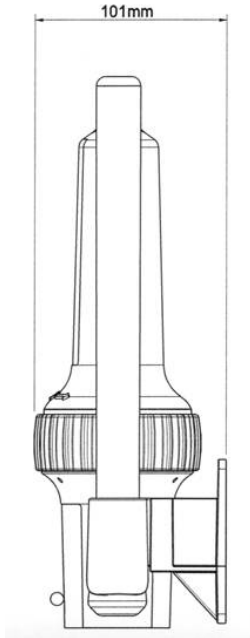
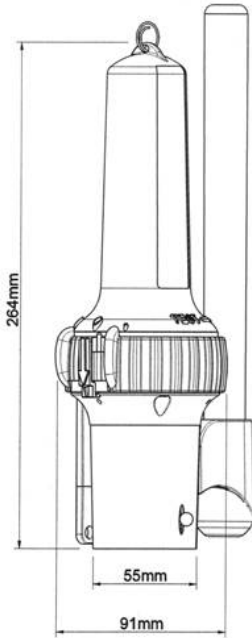

13. Operation of marine radar for SART detection

13.1 Radar Range Scale

When looking for a SART it is preferable to use a range scale between 6 and 12 nautical miles. This is because the spacing between the SART responses is about 0.6 nautical miles (1125 metres) and it is necessary to see a number of responses to distinguish the SART from other responses.

13.2 SART Range Errors

There are inherent delays in the SART responses; the SART has a trigger delay and may also have to sweep through the whole radar band before reaching the frequency of the search radar. At medium ranges of about 6 nautical miles the range delay may be between about 150 metres and 0.6 nautical miles beyond the SART position. As the SART is approached the radar delay of the first dot should be no more than 150 metres beyond the SART position.

13.3 Radar Bandwidth

This is normally matched to the radar pulse length and is usually switched with the range scale and the associated pulse length. Narrow bandwidths of 3.5MHz are used with long pulses on long range and wide bandwidths of 10-25MHz with short pulses on short ranges. Any radar bandwidth of less than 5MHz will attenuate the SART signal slightly so it is preferable to use a medium bandwidth to ensure optimum detection of the SART. The Radar operating manual should be consulted about the particular radar parameters and bandwidth selection.

13.4 Radar Side Lobes

As the SART is approached side lobes from the antenna may show the SART responses as a series of arcs or concentric rings. These can be removed by the use of the anti-clutter sea control although it may be operationally useful to observe the side lobes as these will confirm that the SART is near to the ship.

13.5 Detuning the Radar

To increase the visibility of the SART in clutter conditions the radar may be detuned to reduce the clutter without reducing the SART response. Radar with automatic frequency control may not permit manual detuning of the equipment. Care should be taken in operating the radar detuned, as other wanted navigational and anti-collision information may be removed. The tuning should be returned to normal operation as soon as possible.

13.6 Gain

For detecting a SART at maximum range, the radar should be adjusted to its maximum gain setting.

13.7 Anti-Clutter Sea Control

For optimum range SART detection this control should be set to the minimum. Care should be exercised as targets in sea clutter may be obscured. Some radar sets have automatic/manual anti-clutter sea control facilities in which case the operator should switch to manual.

13.8 Anti-Clutter Rain Control

This should not be used when trying to detect SARTs as the SART responses may be removed by this control. Some sets have automatic/manual anti-clutter rain control facilities in which case the operator should switch to manual.

13.9 Radar Displays

These sketches show the appearance of a SART response at different ranges.

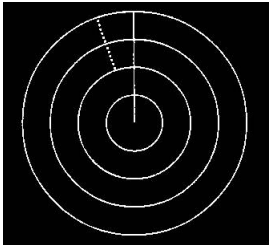

SART response from distant (5-6 miles)

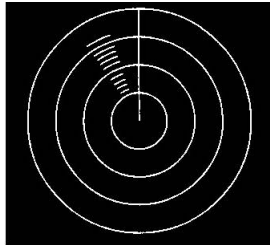

SART response from at medium range (2-3 miles). Note widening of "echoes"

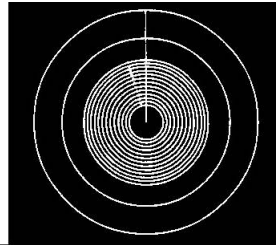

SART response close to vessel (<1 mile). Display now shows "rings" caused by strength of signal

14 Technical Specification

FREQUENCY:	9.2GHz - 9.5GHz
POLARIZATION:	Horizontal
SWEEP RATE:	5 ³ s per 200MHz nominal
RESPONSE SIGNAL:	12 sweeps
FORM OF SWEEP:	Forward: 7.5 ³ s ± 1 ³ s
	Reverse: 0.4 ³ s ± 0.1 ³ s
PULSE EMISSION:	100 ³ s nominal
EIRP:	>400mW (+26dBm)
RX SENSITIVITY:	Better than -50dBm (0.1 mW/m ²) (Note 1)
DURATION:	96 hours in standby condition followed by a minimum 8 hours of transmission while being continuously interrogated with a pulse repetition frequency of 1kHz.
TEMP RANGE:	Operating: -20 ⁰ C to +55 ⁰ C
	Storage: -30 ⁰ C to +65 ⁰ C
RECOVERY TIME:	Following excitation: 10 ³ s or less
ANTENNA HEIGHT:	Greater or equal to 1m (Note 2)
RESPONSE DELAY:	0.5 ³ s or less
ANTENNA BEAM:	Vertical: +/-12.5 degrees
	Azimuth: Omnidirectional to +/-2dB
WEIGHT:	SART only: 360g
	SART + pole: 510g
	SART complete: 530g
DIMENSIONS:	Overall, in bracket: 283 x 101 x 90mm
BUOYANCY:	Buoyant

Note

1. Effective receiver sensitivity includes antenna gain.
2. The effective antenna height applies to equipment required to meet Regulation 6.2.2 of Chapter III and 7.1.3 and 8.3.1 of Chapter IV of the 1988 Amendments to the 1974 SOLAS Convention.

Standards

Complies with IMO Resolution A.802(19)

EC Declaration of Conformity

Hereby Orolia Ltd declares that this EPIRB is in compliance with the essential requirements and other relevant provisions of the Marine Equipment Directive (MED) – 96/98/EC. A copy of the Declaration Of Conformity can be obtained on line from;

www.kannadmarine.com/documents

15 Product Warranty

Kannad Marine is a brand of Orolia Ltd. Subject to the provisions set out below Orolia Ltd warrants that this product will be free of defects in materials and workmanship for a period of two years from the date of purchase. Orolia Ltd will not be liable to the buyer under the above warranty:-

- i for any defect arising from fair wear and tear, wilful damage, negligence, abnormal working conditions, failure to follow Orolia Ltd's instructions (whether oral or in writing) including a failure to install properly and/or to use batteries recommended and/or supplied by Orolia Ltd, misuse or alterations or repair of the product by persons other than Orolia Ltd or an approved service agent;
- i for parts, materials or equipment not manufactured by Orolia Ltd in respect of which the buyer shall only be entitled to the benefit of any warranty or guarantee given by the manufacturer to Orolia Ltd;
- i for the battery storage life which is specifically excluded from this warranty;
- i if the total price for the product has not been paid.

THE LIMITED WARRANTY STATED ABOVE IS EXCLUSIVE AND IN LIEU OF ANY OTHER WARRANTY, EXPRESS OR IMPLIED, INCLUDING BUT NOT LIMITED TO ANY IMPLIED WARRANTY OF MERCHANTABILITY OR FITNESS FOR A PARTICULAR PURPOSE. Orolia Ltd will not be liable for indirect, special, incidental or consequential damages of any kind sustained from any cause. In no event shall Orolia Ltd be liable for any breach of warranty or other claim in an amount exceeding the purchase price of the product. This warranty does not affect any statutory rights of the consumer.

In order to be valid, claims must be made under the above warranty in writing as soon as practicable after discovery of the defect or failure and within the warranty period referred to above. Proof of purchase will be required. The claim should be sent together with the product in question to the address set out below or to an Approved Service Agent.

Following a valid warranty claim Orolia Ltd shall be entitled to repair or replace the product (or part) in question free of charge, or at Orolia Ltd's sole discretion to refund to the buyer the price of the product (or a proportional part of the price). Orolia Ltd shall not be liable to a buyer who is not a consumer for any other loss or damage (whether indirect, special or consequential loss of profit or otherwise) costs, expenses or other claims for compensation which arise out of or in connection with this product. In the case of a consumer Orolia Ltd shall only be liable where other loss or damage is foreseeable.

Nothing shall limit Orolia Ltd's liability for death or personal injury caused by its negligence. This warranty is to be interpreted under English law.

All enquiries relating to this warranty or approved service agents should be sent to:

Orolia Limited, Silver Point, Airport Service Road, Portsmouth, Hampshire, PO3 5PB, UK

Telephone: Int + 44 (0) 23 9262 3900

Fax: Int + 44 (0) 23 9262 3998

Web: www.kannadmarine.com

Email: service.kannad-ma@orolia.com

16 End of Life Statement

At the end of the SART's useful life, it is vital that the battery be disconnected from the main unit to prevent false alarms. False alarms cause expensive disruption to Search and Rescue services and may endanger lives as a consequence. It is also necessary that the SART and its battery pack be disposed of in a manner that does not present a threat of environmental damage.

16.1 Battery Removal

To disconnect the battery, turn the SART over and remove the three battery retaining screws using a cross headed screwdriver. Gently prise the battery from the main unit; Note that this will also release the 'O' ring seal. Cover the terminals of the battery pack with sticky tape to prevent inadvertent short-circuiting.

16.1 Disposal

The Waste Electrical and Electronic Equipment (WEEE) Directive aims to minimise any adverse impact of electronic equipment on the environment, both during the product lifetime and when it becomes waste. Within the European Union this legislation is mandated by Directive 2002/96/EC, and there is similar legislation in most other continents. The directive applies to all electronic products such as IT, household appliances, portable electronics etc., and imposes requirements to collect, treat, recover and recycle each product at its end of life. Electronic end-user products must also carry a WEEE label (as below) and recovery and recycling information has to be provided to the recycler.

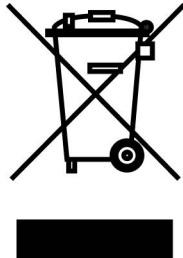

This SART product contains traces of lithium in the battery pack. In addition it may contain lead and brominated flame retardants (BFRs), both in the housing material and circuit boards.

In keeping with the directive, Kannad Marine strongly recommends that this SART product and its battery pack be disposed of in a sensible and considerate manner. For example, do not simply discard the product in the domestic waste. Instead take it to a civil recycling facility, or contact Kannad Marine for advice.

This page is intentionally blank

This page is intentionally blank

Orolia Ltd

Silver Point
Airport Service Road
Portsmouth PO3 5PB
United Kingdom

Phone: +44 (0)23 9262 3900

Fax: +44 (0)23 9262 3998

Email: service.kannad-ma@orolia.com

Website: www.kannadmarine.com

An Orolia Group Business

86-920-002 Issue 2