

Offering high performance, at a low cost, the SmartFind AIS electronics range brings important safety advantages of the Automatic Identification System (AIS) to a wider range of vessels than ever before.

Ideally suited for vessels, where the complexity of an AIS Class A Transponder is not necessary, the McMurdo SmartFind M10 AIS Class B Transponder and SmartFind M15 AIS receiver range will receive and process all AIS targets within 20 miles of the vessel, typical.



## McMurdo SmartFind AIS Electronics Range

The SmartFind M10 AIS Class B Transponder transmits vessel position information and has a built-in GPS receiver to determine the vessel's position, speed and course; and once this is combined with other navigational information, it is automatically transmitted without any user interaction.

Engineered for flawless integration with a wide range of navigation systems, dedicated chart plotters and PC or Mac based software programs, the SmartFind AIS range have advanced interface capabilities, supporting both standard NMEA0183 interfaces as well as USB connectivity, they offer integration with the vessel's other navigation equipment. The SmartFind M10 AIS Class B Transponder also has state of the art NMEA2000 duplex interface capabilities to support the latest generation of NMEA2000 navigation display devices.

The SmartFind M10, also has an SD card slot, which can be used as a data logger, enabling the capture of all messages – to assist in system and safety monitoring, including incident investigation. 4Gb card will store approximately 30 day's worth of data. The 'Silent mode' option, allows the user to temporarily stop the broadcast of identifying information on occasions where either privacy or security is required.

Description	SmartFind M10	SmartFind M10W	SmartFind M15	SmartFind M15S
<b>AIS Type</b>	Class B	CLASS B	RECEIVER	RECEIVER
<b>AIS transmitter</b>	Yes	Yes	No	No
<b>Number of AIS Channels</b>	2	2	2	2
<b>USB</b>	Yes Mini socket	Yes Mini socket	Yes	Yes
<b>NMEA 0183</b>	Independent 2 input 2 output	Independent 2 input 2 output	Independent 1 input 1 output	Independent 1 input 1 output
<b>Built-in VHF/ AIS antenna splitter</b>	No	No	No	Yes
<b>NMEA</b>	Yes	Yes	No	No
<b>SD data logger</b>	Yes	Yes	No	No
<b>Built-in GNSS</b>	Yes	Yes	No	No
<b>Built-in WiFi</b>	No	Yes	No	No

## Specifications for all units

### ENVIRONMENTAL

Operating Temperature:	-15°C-55°C
Storage Temperature	-25°C-70°C
Humidity Operation:	0-95% RH at 40°C
Vibration:	IEC 60945
Waterproof:	IPX2

### PHYSICAL

Width x Height x Depth:	128 x 36 x 88 mm
-------------------------	------------------

### TYPE APPROVAL CERTIFICATION

CE, FCC – M10 models only Check the Seas Of Solutions website for additional type approval information.

### OPERATION

AIS CH-1:	161.975MHz
AIS CH-2:	162.025MHz
Number of AIS Receivers:	2 channel
Message Format:	AIS Class A & B

### POWER SUPPLY

Supply Voltage:	12/24V DC
Power Consumption:	<4 Watt @ 12V

### INTERFACE

VHF Antenna Connector  
Female Type M (PL 259)  
NMEA 0183 (38400 default 4800 bps)  
USB2.0 Supported

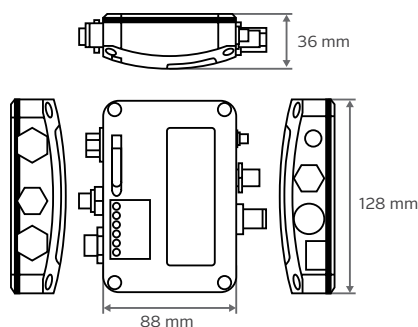

## SmartFind M10

### AIS Class B Transponder

- GNSS
- In built data logger
- NMEA 2000
- NMEA 0183
- USB
- 12/24v DC
- WiFi (M10W version)

## SmartFind M15

### AIS Receiver

- Dual channel
- NMEA
- USB 2.0
- 12/24V DC or USB power
- Compact and economical
- Splitter (M15S version)

## Model Specific Specifications

### M10

Led Indication:	Power, Error, AIS Rx, Tx/Silent, SD
Tx Power Output:	2 Watt (33 dBm ±1.5dB)
Rx Sensitivity:	< 107 dBm @20% PER
NMEA 2000:	Connector
NMEA 0183:	(RS-422), Support two NMEA 0183 interfaces. Baud rate configurable (default 38,400 bps) Separate Tx/Rx baud rate.
Weight:	250g
GNSS:	50 channel, remote GNSS antenna kit included
Wireless connection:	IEEE 802.11 b/g/n (Smartfind M10W only)

### M15

Led Indication:	Power, Error, AIS Rx, Radio Tx (M15S model only).
VHF Radio:	M15S
Female:	Type M (PL 259)
VHF Port Insertion Loss:	M15S
Receiver Pa:	3.5dB
Transmit Path:	1.2dB
Weight:	210g (incl. cable)

USB power option included